

ALDRIDGE

BOSTON V



Traditional shape lanterns for older suburban streets, urban areas and streetscapes

The lantern reflector design eliminates unwanted upward light, providing higher lumination at ground level

APPLICATIONS

- 'V' Cat. Roads
- Intersections
- Large Carparks
- Pedestrian Malls

Features

- Designed to meet stringent Australian Standards
- Self cleaning housing and PMMA optical diffuser
- High Performance LED & Optics to meet AS/NZ1158
- Integrated thermal management
- Hinged 'quick access latch'
- Complies with AS/NZ 1158.6 & AS/NZ 1158.1
- 10 year warranty



Technical Data

- **Body:** High Pressure Die Cast Aluminum
- **Optics:** V Distribution
- **LED #:** 162
- **Wattage:** 75 Watts
- **Finishing:** Powder Coat Black (Black Standard)
- **Mounting:** 6 - 10 Metres
- **Fixing:** Top Spigot Mount (76mm OD)
- **IP rating:** IP65 - IP44
- **IK rating:** IK10
- **Voltage:** 220V - 240V 50/60Hz
- **Power Factor:** >0.9

Options

- **Photocell:** 7-pin Nema receptacle (7PN)
- **Fuse Terminal Block:** (FTB)
- **Surge Protection Device:** (SPD - 10KVA, 20KVA)
- **Class II:** (DB - Double Insulated)
- **Colour:** Green (GR), White (WH), Black (BL-Standard)
- **CCT:** 3000K, 4000K (Standard), 5000K
- **Visor:** Glareshield/spill light kit (GV)

Photometric Design Data

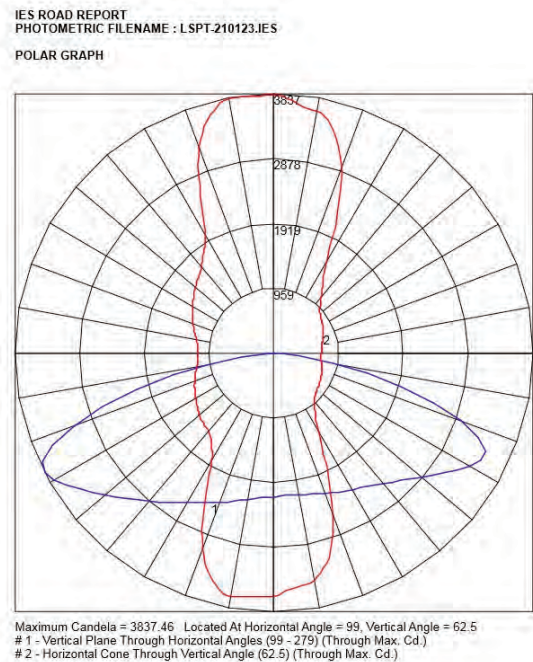

Specification BOSTON V

PRODUCT CODE	BV75WT	BV75WS
Description	Top Entry	Side Entry
System Watts	75	75
Input Voltage	220V - 240V 50/60Hz	220V - 240V 50/60Hz
CCT (K)	4000	4000
CRI	Ra>75	Ra>75
IP Protection	IP65 - IP44	IP65 - IP44
IK Protection	IK06	IK06
Weight (Kg)-max.	10kg	10kg

Dimensions



Top Entry

Side Entry

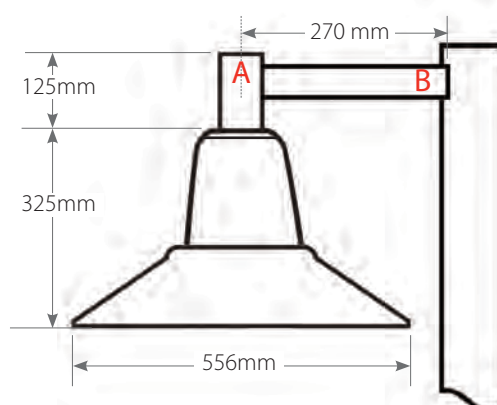
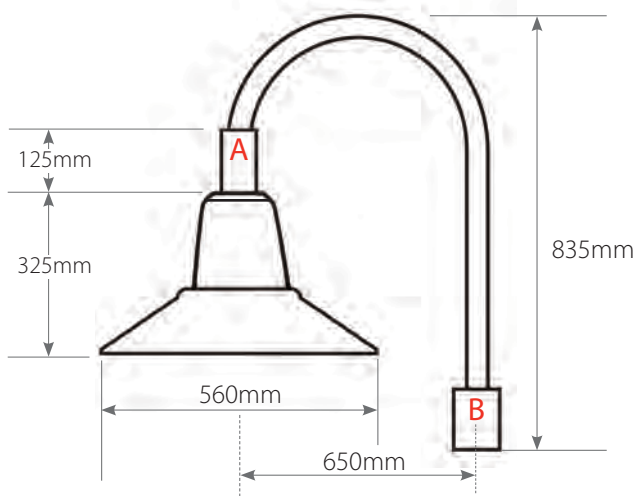

From the Brand You Know and Trust for Over 40 Years



ALDRIDGE

Aldridge Traffic Systems Pty Ltd

12 - 14 Leeds Street
Rhodes NSW 2138

www.aldridgetraffic.com.au

NSW

P: +61 2 9736 3677
F: +61 2 9736 3391
e: info@traffictld.com.au

VIC

P: +61 3 9430 0222
F: +61 3 9430 0244
e: info@traffictld.com.au

SA

P: +61 8 8362 2385
e: info@traffictld.com.au

NT

P: +61 8 8947 0733
F: +61 8 8947 0713
e: info@traffictld.com.au

ACT

P: +61 2 6299 7922
F: +61 2 6299 7977
e: info@traffictld.com.au

WA

P: +61 8 9248 1002
F: +61 8 9209 2288
e: info@traffictld.com.au

QLD

P: +61 7 3266 1900
F: +61 7 3266 2244
e: info@traffictld.com.au

TAS

P: +61 3 6273 1177
F: +61 3 6273 1759
e: info@traffictld.com.au

UNITED KINGDOM

P: +44 (0) 1159 223 797
F: +44 (0) 1159 223 836
e: info@aldridgetraffic.co.uk