

ALDRIDGE

Intelligent Traffic Systems



Product Catalogue

WHAT WE OFFER

DESIGN & BUILD

Aldridge can help you find the best and most cost effective solution to your traffic management issues. We have extensive experience, technology and resources at our disposal that will enable us to design, build and even install the right solution for you.

PROJECT MANAGEMENT

Our experienced in-house Project Management team can take full control of your traffic management solution projects to ensure that projects are completed on time and within budget, from manufacture to installation, for optimum product functionality.

SERVICE & MAINTENANCE

Regular and competent service and maintenance of traffic management products is a cornerstone of increased product life, functionality and return on investment. As designers, manufacturers and installers of traffic management solutions, Aldridge is best placed to deliver high value service and maintenance works for those products.

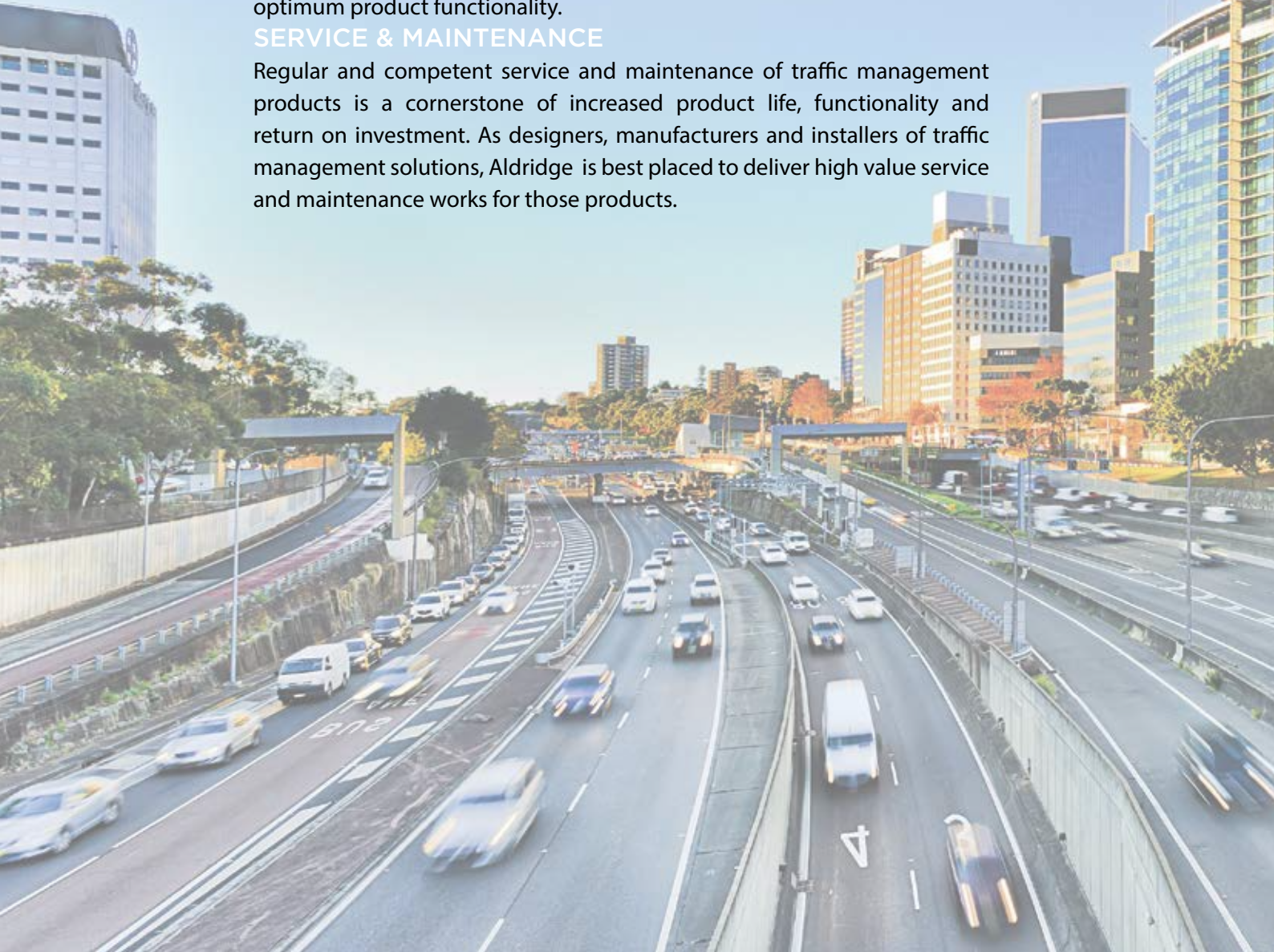

TEMPORARY TRAFFIC MANAGEMENT	page
eSTOP – Portable Traffic Signal	4
eSTOP Standard	5
eSTOP Multi	5
eSTOP Auto	6
eSTOP Crossing Scenarios	7
Speed Indication Device Trailers	
EVOLIS	8
VEHICLE ACTIVATED SIGNS	
VAS General	10
EVOLIS	12
ENHANCED STATIC SIGNS	
Overview	14
VEHICLE DETECTION / SENSOR TECHNOLOGY	
Over Height Detection	16
Intelligent Sensors	17
Rain and Flood Detection Sensors	18



eSTOP



Australia's first Type 1 approved Portable Traffic Signal System (PTSS), the eSTOP™ is the new benchmark for road safety. Made mandatory in certain States for high speed and high risk worksites, trials conducted by a tier one roading company showed use of the eSTOP™ resulted in a staggering 93% reduction of near misses.

BENEFITS

- Monitor, maintain and manage your signs from any PC, laptop, tablet or smartphone
- Replaces stop/slow baton with remote controlled traffic lantern
- Enables traffic controllers to perform duties safely away from live traffic
- Remove controllers from facing abuse and hydration related risks
- Reduces near misses by up to 93%
- The most widely used PTSS across Australia and New Zealand.

Viewing distance:

It stands out can be viewed from a greater distance, giving motorists more time to react.

Greater visibility:

In low light, overcast and foggy conditions, motorists can not see traffic controllers, but they don't miss the eSTOP™.

Sun safety:

Traffic controllers can stand in the shade away from harmful rays, fatigue and dehydration.

Portability:

The eSTOP™ provides a more portable, easier to deploy alternative to heavy and hard to handle trailer mounted traffic lights.

Time tested reliability:

Invented in 2016, the eSTOP™ has been built to the highest standards and time tested for endurance and performance.



SAVE LIVES AND REDUCE INJURIES WITH eSTOP

Keep your Traffic Controllers out of danger with the Aldridge portable traffic signal system.



eSTOP™ STANDARD

In its standard configuration, each eSTOP™ lantern can be controlled either by one person when PAIRED, or two people when independently PAIRED.

In PAIR mode one traffic controller can control two lanterns at the same time using the Hand Remote Controller (HRC), in this mode of operation, the fail-safe feature ensures no two green lanterns are on at the same time.

eSTOP™ STANDARD MULTI

Provides all features of the eSTOP™ Standard but with the ability to control up to 4 lanterns with a single HRC. In Multi Pair mode, one button will control two lanterns simultaneously.

For example, when deployed on one end of a two-lane road to ensure visibility for both lanes, or to control the exit of a construction site and temporarily close all traffic when mobile plants leave.

FEATURES

- Type 1 approved across Australia and New Zealand
- Fail-safe feature to prevent 2 green lanterns at the same time
- Tilt and rotation alarms
- Ergonomic design with robust, light weight components of max 8.4 kg
- Portable and easy to assemble
- Integrated target board (compulsory in NSW & NZ)
PATENT ID 2020100318
- 15 hours battery life
- Small Hand Remote Controller (HRC), UV protected, rated IP65 with range of up to 400 m, able to control up to 2 lanterns
- Handling protection, IP65 rated cable connections at all device parts to make reverse connections impossible
- Adjustable tripod legs for uneven surfaces, adjustable height
- Wind-load tested
- Fully encrypted for advanced cybersecurity

eSTOP

eSTOP™ AUTO Patent Application ID: 2020901429

Simple to use, the eSTOP™ AUTO applies the pre-programmed logic and regulates traffic under human supervision.

The embedded vehicle radar ensures shortest possible waiting times and can overrule “green” periods when no vehicle is approaching to let the waiting vehicle on red proceed. A countdown embedded in the yellow traffic light engages with waiting motorists to avoid situations of jumping the red light, or frustrated motorists.

Based on the most deployed eSTOP™ solution across Australia and New Zealand – the eSTOP™ AUTO is extremely portable allowing for fast deploy providing frontline workers safer work environments in situations where they would otherwise have to work without any traffic control solution; such as emergency jobs and working on road bends.

FEATURES

Provides all features of the eSTOP™ Standard, plus the following:

- Easy and simple configuration of waiting and clearance time via latest HRC X
- Human supervision only, no human intervention required after activation of AUTO mode
- Ability to operate in AUTO and MANUAL mode Up to 2km distance with clear line of sight
- Vehicle actuated: override Auto mode when vehicle is detected (available as option)

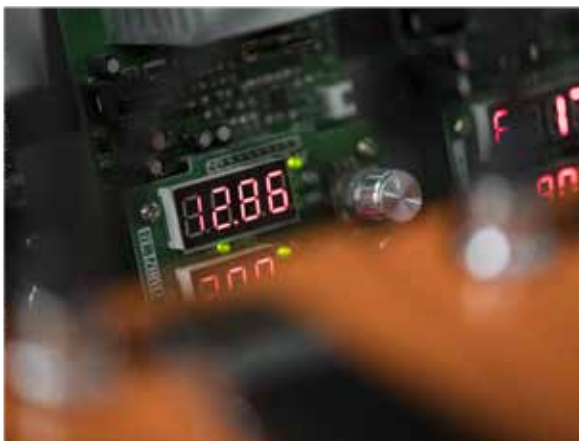

OPTIONS

Bags:

Protective, secure and easy to carry hard case for lanterns, target boards, batteries and tripod legs.

Camera:

Front and rear camera recording providing further protection for front line workers and evidence in insurance cases. Camera footage includes GPS location, time-stamp as well as indicating traffic light status. Recording on embedded SD card.

Target Board: Patent ID 2020100318

Mandatory for NSW & NZ.

Vehicle Actuation:

(For eSTOP™ AUTO only) Patent Application ID: 2020901429

Reduces motorists waiting time; for example by extending GREEN period in case of no queuing vehicle on RED side.

HRC X up to 2km range Patent Application ID: 2020901429

Up to 2km range with clear line of sight.

Mobile car battery charging kit:

Equipment required to charge eSTOP™ batteries while in the field.



eSTOP Multi use case scenarios

eSTOP™ Plant Crossing States

State 1

Unit 1 green = work vehicles to cross.
Unit 2s both red = all traffic stops.

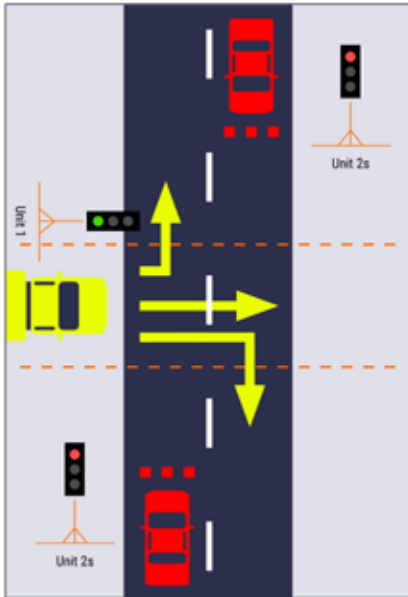

State 2

Unit 1 red = work vehicles stopped.
Unit 2s both green = all traffic flowing.

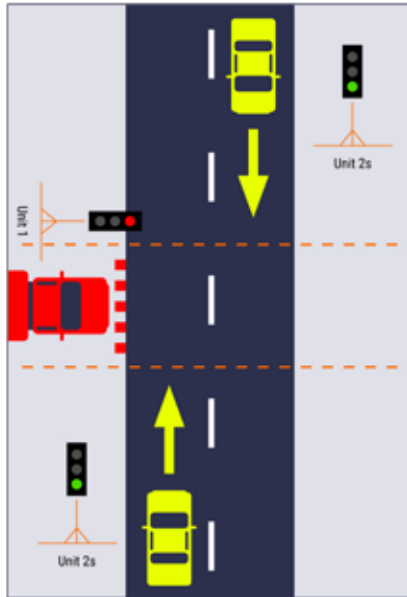

NB. Unit 2s lantern colour must always match

eSTOP™ Multi Duplicate Light States

State 1

Unit 1s both green = south traffic flows.
Unit 2s both red = north traffic stops.

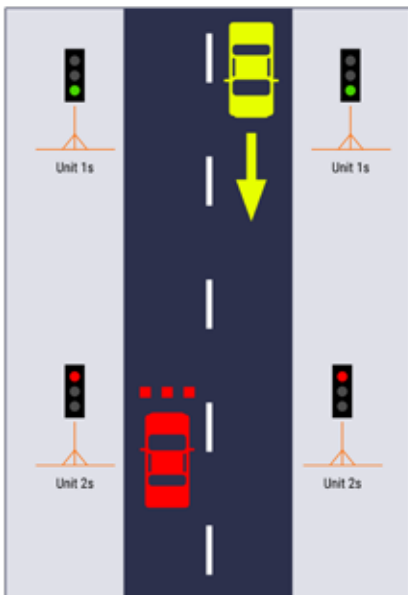

State 2

Unit 1s both red = south traffic stops.
Unit 2s both green = north traffic flows.

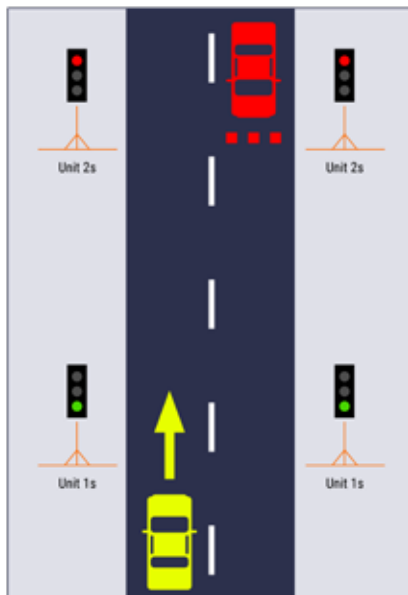

State 3 - Intersectional

Unit 1s both green = north & south traffic flows.
Unit 2s both red = east west traffic stopped.

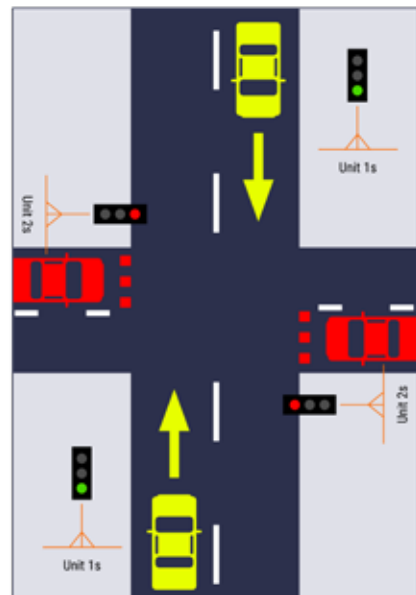

Speed Indication Device Trailers



'EVOLIS' - EUROPEAN DESIGNED AND MANUFACTURED

With more than 8000 units installed world-wide, the Evolis Speed Indication Device is the product of choice for an all in one radar and data collection device. Not only does it present a sleek European design, it has also been built using the best components giving it a reputation for being one of the most energy efficient and reliable units in the market.

The Evolis Speed Indication Device is easily configured and installed to educate motorists of their travel speeds. It helps to reduce overall excess traffic speeds, particularly in high incident areas. Utilising the optional built in data logger, road asset owners can gather and analyse traffic speed data on specific roads so that they can make informed planning decisions on road safety.

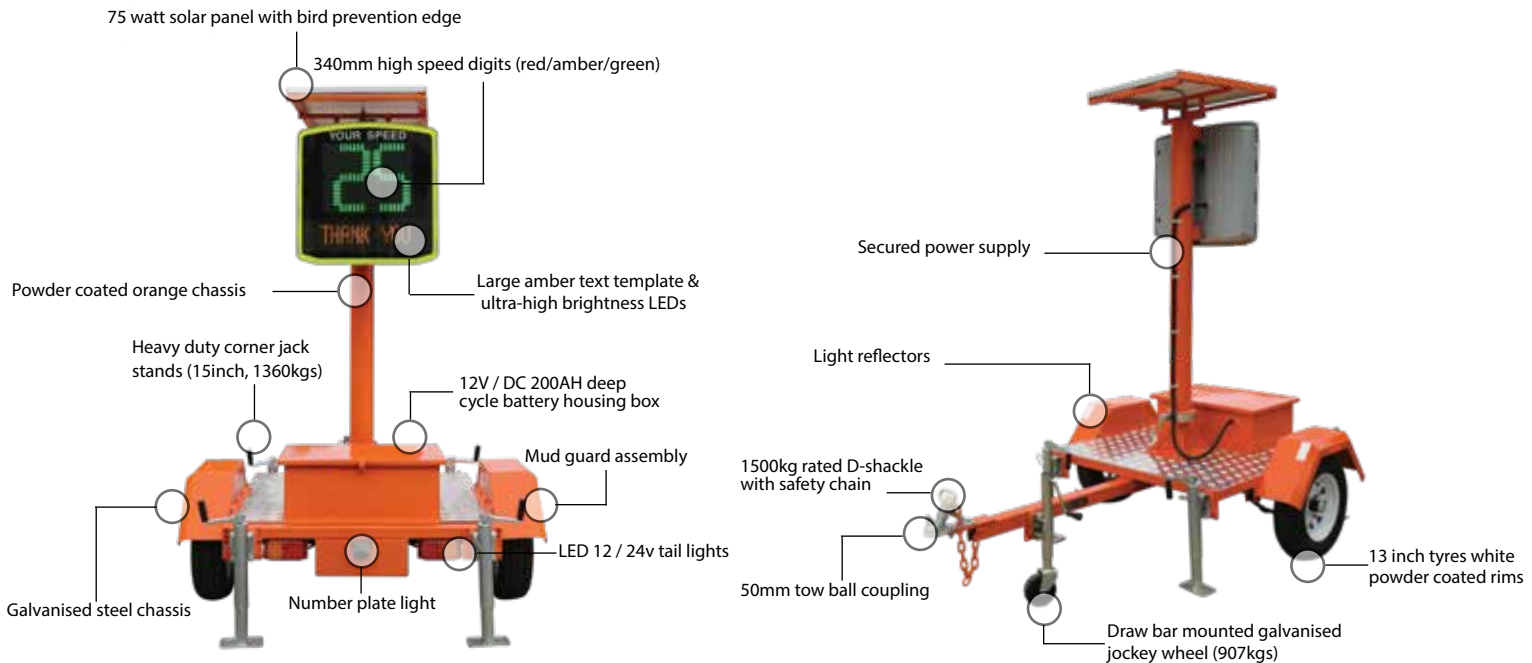

FEATURES & BENEFITS

- Anti-corrosion, anti-UV treatment plus unit sealing ensures long term resistance, strength and durability.
- Injected ABS resin waterproof housing with integrated hooks.
- Lockable permanent mounting bar made of injected ABS resin, mounted on poles with brackets (sold separately).
- Front face made of tough polycarbonate, fixed to the casing with mechanical clip and gasket seal.
- Waterproof IP66 housing for 2 batteries, USB port, dial selector and adapter.
- Installed in minutes by one person.
- Optional 1 or 2 way traffic flow statistics.
- Optional pre-configured speed/text display settings prior to installation.
- Accompanying EVOCOM software for settings configuration plus data analysis.
- 34cm high speed digits (red/amber/green), a large amber text template and ultra-high brightness LEDs.



OPTIONAL EXTRAS

- Bluetooth Connection
- 4G Connection
- One way Traffic Flow Statistics
- Two way Traffic Flow Statistics

RADAR SENSOR

Doppler Radar:	24.125 Ghz
Detection range:	10-250 metres
Detection angle:	17 °
Accuracy:	+/- 1km/h (traveling at 100km/h)

DISPLAY

LED:	3 digits
Colors:	Red, Amber and Green
Size of digits:	340mm
Text display (Matrix):	640mm x 160mm (64 x 16 pixels)
	1 line of 7 characters 160mm high
	2 lines of 10 characters 70mm high
Visibility:	250m
Refresh:	1.2 seconds (configurable)

HOUSING

Dimensions:	H: 700mm x W: 709mm x D: 170mm
Housing:	Injected ABS resin, grey RAL 7035
Front face:	Polycarbonate
Waterproof:	IP66
Weight:	8kg (without batteries)

EVOCOM SOFTWARE

Advanced Configuration & Statistic Analysis

Evocom PC software, provided free of charge, is featured with a user-friendly interface for advanced configuration: specific speed ranges, speed increments, data recording function (*), text messages, time slots etc...

(*)Data recording function (one way / two way traffic flow statistics) purchased separately.

Settings configuration screen

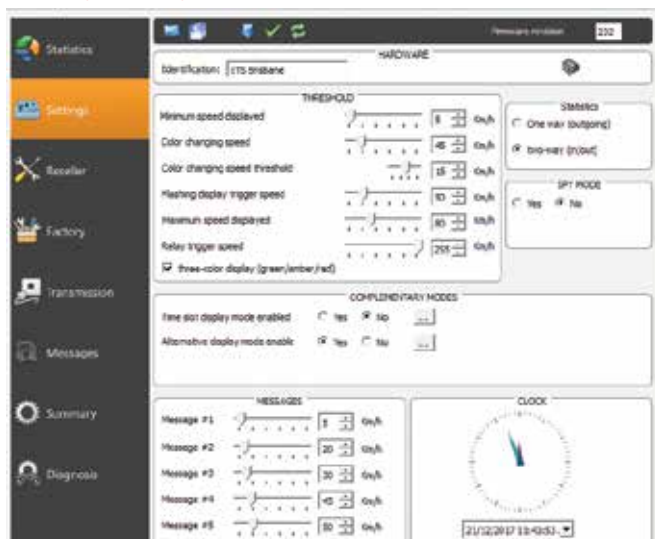

Vehicle Activated Signs (VAS)

VAS TO SUIT YOUR APPLICATION NEEDS

Vehicle Activated Signs offer solutions that provide direct feedback to drivers to give advanced warning of an approaching crossing, curve, intersection or to notify the driver they are exceeding the speed limit within certain areas. These signs can be full LED matrix panels

or a combination of a static sign with LED modules. We work with you to design the sign to your requirements and ensure it operates at maximum efficiency and reliability. We come to site to commission the sign and as always offer full technical support following installation.



EXAMPLE PRODUCT CONFIGURATION

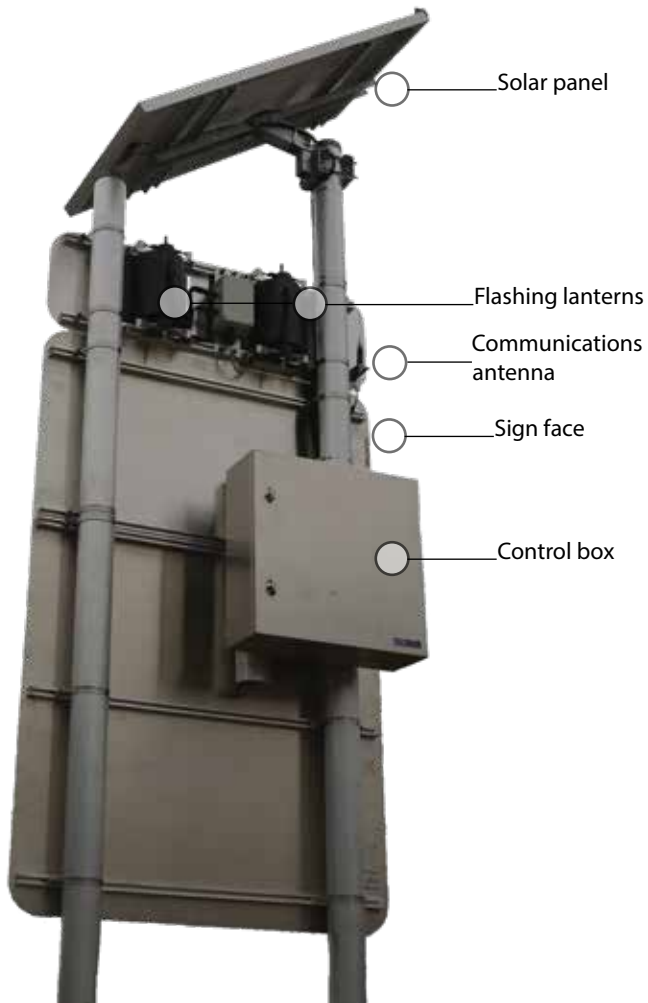

- No maintenance Gel batteries
- IEC 61215 approved solar panels
- Multi-Crystal cell solar panel construction
- AS-2144 compliant Amber LED beacons
- Manual or remote activation
- Stainless steel enclosure
- Australian compliant road signs

SIGN TRIGGERING

- Calender: Set to time / date schedules
- Clock: Set to time schedules
- Radar: Set to vehicle detection
- Constant: 24hrs / day
- Speed: Set to speeding vehicles



Evolis

EUROPEAN DESIGNED & MANUFACTURED

With more than 8000 units installed world-wide, the Evolis Speed Indication Device is the product of choice for an all in one radar and data collection device. Not only does it present a sleek European design, it has also been built using the best components giving it a reputation for being one of the most energy efficient and reliable units in the market.

The Evolis Speed Indication Device is easily configured and installed to educate motorists of their travel speeds. It helps to reduce overall excess traffic speeds, particularly in high incident areas. Utilising the optional built in data logger, road asset owners can gather and analyse traffic speed data on specific roads so that they can make informed planning decisions on road safety.



FEATURES & BENEFITS

- Anti-corrosion, anti-UV treatment plus unit sealing ensures long term resistance, strength and durability
- Injected ABS resin waterproof housing with integrated hooks
- Lockable permanent mounting bar made of injected ABS resin, mounted on poles with brackets (sold separately)
- Front face made of tough polycarbonate, fixed to the casing with mechanical clip and gasket seal
- Waterproof IP66 housing for 2 batteries, USB port, dial selector and adapter
- Installed in minutes by one person
- Optional 1 or 2 way traffic flow statistics
- Optional pre-configured speed/text display settings prior to installation
- Accompanying EVOCOM software for settings configuration plus data analysis
- 34cm high speed digits (red/amber/green), a large amber text template and ultra-high brightness LEDs



Optional Extras

- Bluetooth Connection
- 4G Connection
- One way Traffic Flow Statistics
- Two way Traffic Flow Statistics

RADAR SENSOR

Doppler Radar:	24.125 Ghz
Detection range:	10-250 metres
Detection angle:	17 °
Accuracy:	+/- 1km/h (traveling at 100km/h)

DISPLAY

LED:	3 digits
Colors:	Red, Amber and Green
Size of digits:	340mm
Text display (Matrix):	640mm x 160mm (64 x 16 pixels)
	1 line of 7 characters 160mm high
	2 lines of 10 characters 70mm high
Visibility:	250m
Refresh:	1.2 seconds (configurable)

HOUSING

Dimensions:	H: 700mm x W: 709mm x D: 170mm
Housing:	Injected ABS resin, grey RAL 7035
Front face:	Polycarbonate
Waterproof:	IP66
Weight:	8kg (without batteries)

EVOCOM SOFTWARE

Advanced Configuration & Statistic Analysis

Evocom PC software, provided free of charge, is featured with a user-friendly interface for advanced configuration: specific speed ranges, speed increments, data recording function (*), text messages, time slots etc...

(*)Data recording function (one way / two way traffic flow statistics) purchased separately.

Settings configuration screen

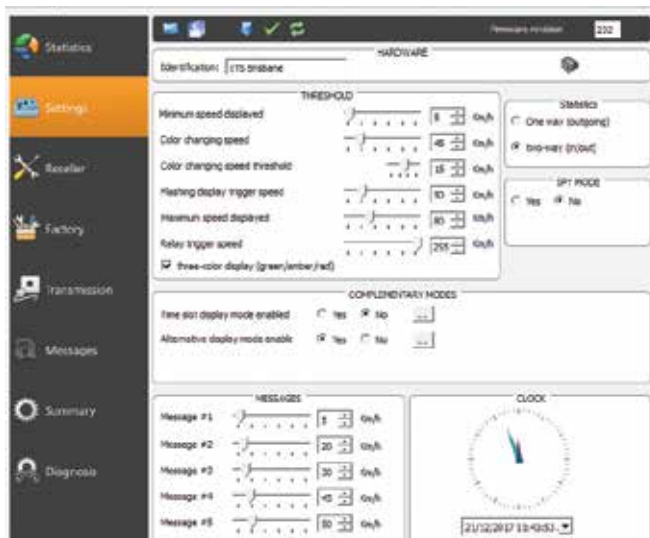

Enhanced Static Signs

SIGNS TO SUIT YOUR APPLICATION NEEDS

Enhanced Static Signs offer solutions that provide direct feedback to drivers to give advanced warning of an approaching crossing, curve, intersection or to notify the driver of road closures within certain areas. These signs consist of a combination of a static sign with LED modules. They have a proven track record of being more effective than a static

sign alone. We work with you to design the sign to your requirements and ensure it operates at maximum efficiency and reliability and complies with relevant Australian standards. We come to site to commission the sign and as always offer full technical support following installation.



EXAMPLE PRODUCT CONFIGURATION

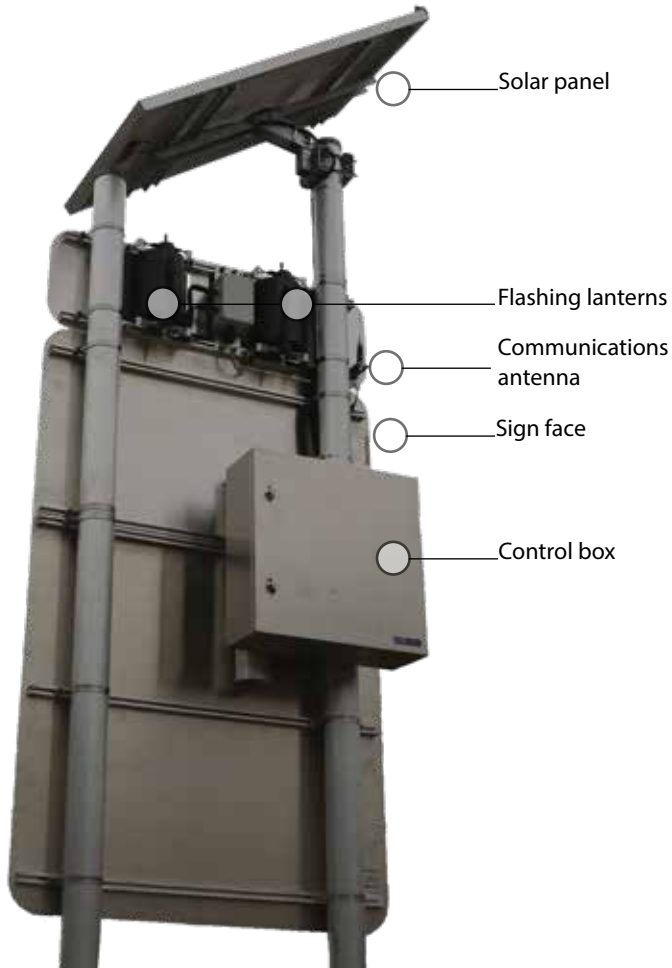

APPLICATIONS

- Flooding
- Cane Railway
- Slippery Roads
- Trucks (crossing or turning)
- Falling Rocks
- Stock Crossing
- Changed Roadwork Conditions
- School, Pedestrian or Roadwork Zones
- Road Closures or Detours
- Traffic Control
- General Hazards

- No maintenance Gel batteries
- IEC 61215 approved solar panels
- Multi-Crystal cell solar panel construction
- AS-2144 compliant Amber LED beacons
- Manual or remote activation
- Stainless steel enclosure
- Australian compliant road signs

VEHICLE DETECTION / SENSOR TECHNOLOGY

OVER-HEIGHT DETECTION

Preventing high value assets such as bridges and tunnels from being struck by over-height vehicles. The solution saves time, money and also many unseen downstream effects that impact business, insurance and the community in general as a result of the asset being struck. Installing a reliable vehicle over-height detection system prior to a bridge or tunnel can instantly activate

downstream warning devices that can alert the operator of the vehicle of the danger ahead therefore prompting them to take evasive action. In most cases it only takes the prevention of one significant impact to pay for an entire over-height detection system making the return on investment extremely fast.



APPLICATIONS

- Detection of vehicles that are too high to pass under bridges or enter tunnels
- Detection of over-height vehicles and corresponding lanes
- Detection of ships or boats that are too high to pass under bridges
- Vehicle travel direction detection
- Wrong Way traffic detection

SYSTEM COMPONENTS





- Infrared beam transmitters & receivers
- Electronic warning sign
- Uninterruptible power supplies
- Inductive traffic loop
- Optional video
- Optional traffic counter



INTELLIGENT SENSORS

Latest technology sensors used for a multitude of applications; pedestrian detection, traffic detection, stop line detection, pedestrian wait area detection, multi-lane roadway detection and more. Sensors can be used

to measure vehicle speed, vehicle range, vehicle length, classification, movement and vehicle counts. They can be paired with smart signs to create smart work zones.

<p>Intersection Control</p>	<p>Vehicle Activated Sign Driver</p>	<p>Temporary Applications</p>
		
<p>Low Power Applications</p>	<p>Vehicle Count</p>	<p>Single Lane Stop Line</p>
		
<p>Pedestrian Area Detectors</p>	<p>Multi-Lane Highway Detectors</p>	
		

VEHICLE DETECTION / SENSOR TECHNOLOGY

RAIN SENSORS: FLOOD DETECTION AND WARNING SYSTEMS

Flash flooding is increasingly becoming a regular occurrence in Australia so it is becoming a vital requirement to incorporate sensor technology giving motorists advanced warning of potential flood zones. The solution is a combination of technologies, each of which can be used independently or combined to

provide a comprehensive monitoring warning system for roads subject to flooding. Smart signs are automatically activated via local water level measurement triggers or rain sensors. SMS messages are sent to notify stakeholders of the road status.



WHO WE ARE

Aldridge Traffic Systems is an Australian company, owned by Traffic Technologies Ltd. (ASX TTI). Aldridge is at the forefront of the Intelligent Transportation Systems industry.

Aldridge's sister company DeNeefe Signs, is the oldest, most respected and recognised road sign manufacturer in Australia. Since 1926 DeNeefe have been providing static road signage and traffic management solutions to every state and territory.

Aldridge Intelligent Traffic Systems provide additional and specific LED Signage information enabling motorists to make informed decisions in a relevant and timely manner. Aldridge's road management solutions can, in consultation with all stakeholders, provide a tailored solution that works for you.

Call our consultants on 1300 769 852 to discuss your next project.

Informed motorists create safer and smoother traffic flows on our road network.

ALDRIDGE INTELLIGENT TRAFFIC SYSTEMS

ENHANCED SAFETY PRODUCTS

- Enhanced Road Signs
- Fixed Static LED Signs
- LED Enhanced School Zone Signs
- Driver Feedback Signs
- Speed Indication Device Signs
- Vehicle Activated Speed & Warning Signs
- Vehicle Over-Height Detection
- Flood Detection Warning Signs



ALDRIDGE

Aldridge Traffic Systems Pty Ltd

12 - 14 Leeds Street
Rhodes NSW 2138

www.trafficltd.com.au

NSW

P: +61 2 9736 3677

e: info@trafficltd.com.au

VIC

P: +61 3 9430 0222

e: info@trafficltd.com.au

SA

P: +61 3 9430 2666

e: info@trafficltd.com.au

NT

P: +61 8 8947 0733

e: info@trafficltd.com.au

ACT

P: +61 2 6299 7922

e: info@trafficltd.com.au

WA

P: +61 8 9248 1002

F: +61 8 9209 2288

e: info@trafficltd.com.au

QLD

19/15 Holt Street
Pinkenba, QLD 4008

P: 1300 769 852 *or*

P: +61 7 3266 1900

e: info@trafficltd.com.au

TAS

P: +61 3 6273 1177

e: info@trafficltd.com.au

UNITED KINGDOM

P: +44 (0) 1159 223 797

e: info@aldriggetraffic.co.uk

